

CONTRACT NO.		COMPANY NAME	
APPROVALS	DATE	IUT de nice dpt GEII	
DRAWN	10/10/02	SIZE	DWG
CHECKED		PROGRAMMEUR	altera
ISSUED		FSCM NO.	DWG NO.
		SCALE	SHEET
			1/1

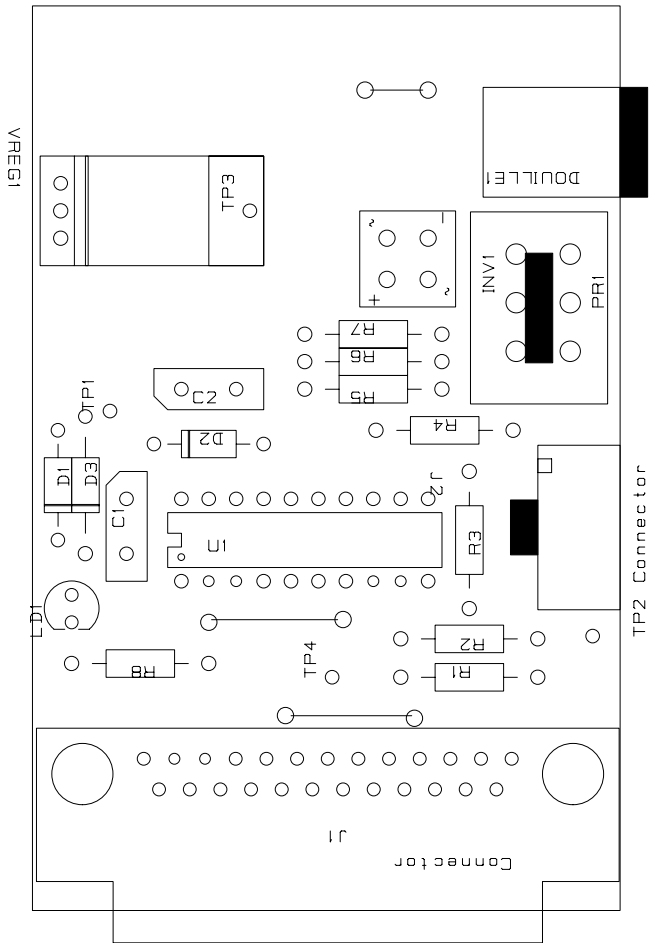

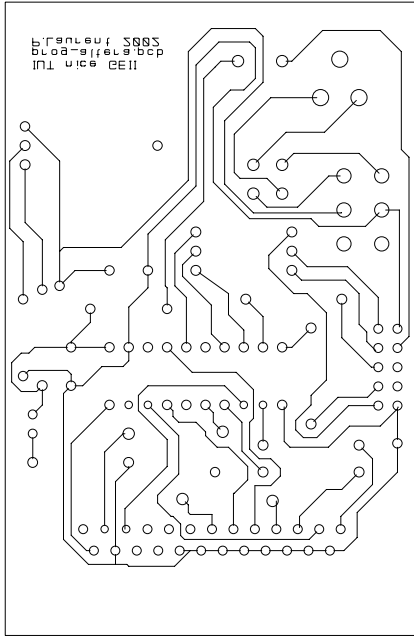

Parts List

Cadstar Design Editor Version 3.0.3

Design: Z:\sujet_tr1\prog_altera.pcb

Design Title:
Cadstar PCB Design - 2 Layer Defaults

Date: mardi 7 octobre 2003
Time: 17:12

testeur de batteries

Part Name	Part Number	Description	Qty.	Comps.
-----	-----	-----	-----	-----
100N PLASTIC			2	C1-2
1N4001		DIODE	1	D3
1N4148		DIODE	2	D1-2
33-5%-TR4		33R TR4 METAL OXIDE FILM 5%	7	R1-7
330-5%-TR4		330R TR4 METAL OXIDE FILM 5%	1	R8
74HCT244		OCTAL LINE DRIVER/REC BUFFERS	1	U1
DB25_mal	coude		1	J1
DOUBLE_INVERSEUR_CI		double inverseur pour ci	1	INV1
DOUILLE_ALIM_35		douille alimentation 3,5mm	1	DOUILLE1
HE10_MAL			1	J2
LED 3MM ROUGE			1	LD1
LM7805CT		+5V, 1AMP REGULATOR	1	VREG1
PONT_RED_ SW08		PONT REDRESSEUR FAIBLE INTENSI	1	PR1
Testpoint			4	TP1-4

End of report
